

# Fyfield Parish Council

Clerk to the Council;  
Derek Farr

email:caliban@gmx.co.uk

---

## AGENDA

You are summonsed to a meeting of Fyfield Parish Council to be held on Monday 12 September 2016 to be held at Fyfield Village Hall at 8:30pm, to complete the business shown on the agenda below.



Derek Farr  
Parish Clerk  
7 September 2016

### **1. Apologies for absence**

To receive any apologies.

### **2. Declaration of Interests**

To receive any declarations of interest. Members are invited to confirm whether interests are pecuniary or non pecuniary. Further advice is available before the meeting from the Clerk.

### **3. Confirmation of the Minutes of the Council meeting held on 8 August 2016.**

A copy of the draft minutes is attached to the agenda.

### **4. Questions and statements from members of the public**

The time allocated for public questions shall be limited to 15 minutes, unless varied by the Chairman of the meeting.

### **5. Essex Association of Local Councils - Annual General Meeting**

To receive and consider the invitation to the event on 22 September. Details are attached to the agenda.

### **6. Local Highways Issues**

To raise and consider any current local maintenance issues.

### **7. Renewal of Insurance Policy**

To note the renewal of insurance cover for the Parish Council. A verbal report will be provided by the Clerk.

### **8. Local Environmental Issues**

To consider any current local environmental issues

### **9. Progress with the review of the relationship between the Parish Council, the Village Hall and the Sports and Social Club**

The Clerk will provide a report on progress with the appointment of legal advisors for the Parish Council.

## **10. Planning Matters;**

### ***a) Planning Applications***

To consider the following planning application received;

**Application No:** EPF/2204/16

**Applicant Name:** Mr B Carpenter

**Location:** Lestrem

Dunmow Road

Fyfield

Ongar

Essex

CM5 0NN

**Proposal:** Two storey side extension

Details of the application are attached to the agenda

### ***b) Local Plan***

To receive a report from the Clerk on progress with the new Local Plan

## **11. Financial Reports;**

### ***a) Approval of expenditure.***

Members approval is sought for the list of expenditure items (to be circulated under seperate cover).

### ***b) Budget update***

To receive a report on income, expenditure and cash in hand as provided by the Clerk, (to be circulated before the meeting under seperate cover).

## **12. Date of the next meeting**

To confirm details for the next meeting.



<b>E</b>	<b>Enabling &amp;</b>
<b>A</b>	<b>Assisting</b>
<b>L</b>	<b>Localism in</b>
<b>C</b>	<b>Councils</b>



**ESSEX ASSOCIATION OF LOCAL COUNCILS**  
**ANNUAL GENERAL MEETING**  
**ON THURSDAY 22ND SEPTEMBER 2016**  
**START TIME - 12.30PM**  
**DOORS OPEN AT 11.30AM**

&

**ESSEX COUNTY COUNCIL &**  
**ESSEX ASSOCIATION OF LOCAL COUNCILS**  
**ANNUAL CONFERENCE**  
**CONFERENCE COMMENCES AT 2.30PM**

**VENUE: FOAKES MEMORIAL HALL,**  
**STORTFORD ROAD, DUNMOW,**  
**ESSEX, CM6 1DG**

## **Doors open 11.30am -**

Light Refreshments available

Stands/Early Bird Draw

Enjoy visiting stands and networking with colleagues.

**Sponsored by AJ Lighting**

## **AGM 12.30pm**

Presentation of the EALC Annual Report/Financial Report and setting the affiliation fee 2016/17. Motions received by noon on Tuesday 23rd August will be debated. Make sure your Council is represented, to take part in the proceedings. Each Council may have two voting members.

## **1.30pm Lunch will be served.**

## **Conference starts 2.30pm**

The Conference this year is Chaired by Cllr Mick Page - Deputy Cabinet Member for Planning & Rural Affairs and Cllr John Gili-Ross the EALC Chairman.

## **2.40pm**

Cllr Kevin Bentley - Deputy Leader and Cabinet Member for Economic Growth and Partnerships.

Future Partnership Working.



## **3.05pm**

Roger Hirst Police and Crime Commissioner for Essex.  
Presentation and Questions.



## **3.30pm**

Stephen Kavanagh Chief Constable  
Essex Police.

Presentation and Questions.



### **3.50pm**

Tim Morris FICCM(Dip) - C/E of the Institute of Cemetery and Crematorium

Management will be giving a presentation on "A Working Life in Death".



## **Awards + Raffle**

### **4.15pm**

- Buckingham Palace - An Award in Recognition of the work of Chairman or Past Chairman. (The winner of this Award will receive 2 tickets to attend a Garden Party in 2017, (subject to EALC receiving their normal allocation).
- EALC Council of the Year Award
- Village of the Year Award
- Other special Awards for Individual Achievements
- The EALC Executive Raffle

Each year the EALC Executive provides a raffle to raise funds to meet the cost of this event.

### **5.30pm**

Event to be closed.

**Planning Application EPF/2204/16**

**Lestrem, Dunmow Road, Fyfield, Ongar Essex CM5 0NN**

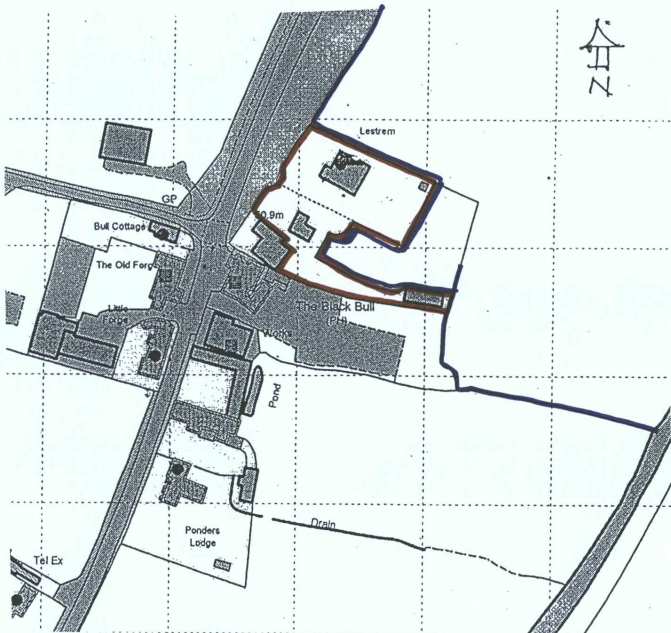

**Location Plan**

Scale 1:1250

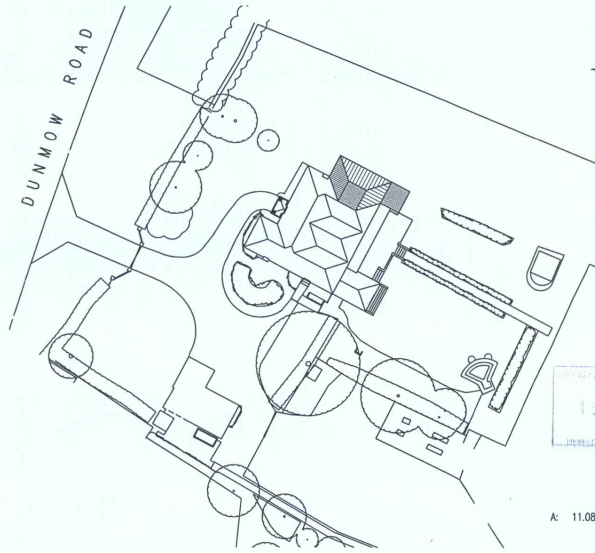
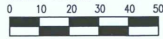

**Site Plan**

Scale 1:500

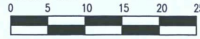

A: 11.08.16 Enlarged size of proposal

**JSP Chartered Town Planners and Design Consultants**

1 Babsons Yard,  
High Street, Ongar,  
Essex CM5 9AA  
T 01277 368886  
F 01277 368864



Site Lestrem, Dunmow Road,  
Fyfield, Ongar CM5 0NN  
Title Proposed 2 storey side  
extension  
Drawing Location & Block Plan  
Scale 1:1250 and 1:500 @ A3  
Date Apr 2016  
Number 878.20A

**Existing Elevations**



Rear Elevation



Front Elevation

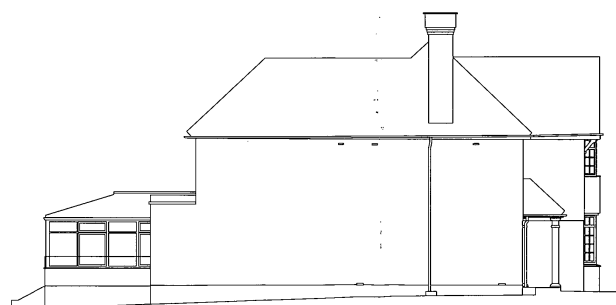

Side Elevation



Side Elevation



**JSP Chartered Town Planners and Design Consultants**  
1 Babsons Yard,  
High Street, Ongar,  
Essex CM5 9AA  
T 01277 368886  
F 01277 368864



Site Lestrem, Dunmow Road,  
Fyfield, Ongar CM5 0NN  
Title Proposed 2 storey side  
extension  
Drawing Existing Elevations (1 of 2)  
Scale 1:100 @ A3  
Date Apr 2016  
Number 878.23

# Proposed Elevations



Front Elevation



Side Elevation

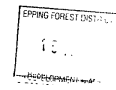

A: 11.08.16 Enlarged size of proposal



**JSP Chartered Town Planner  
and Design Consultants**  
1 Bantons Yard,  
High Street, Ongar,  
Essex CM5 9AA  
T 01277 366886  
F 01277 366864



Site Lestrem, Dunmow Road,  
Fyfield, Ongar CM5 0NN

Title Proposed 2 storey side  
extension

Drawing Proposed Elevations (1 of 2)

Scale 1:100 @ A3  
Date Apr 2016  
Number 878.27A



Rear Elevation

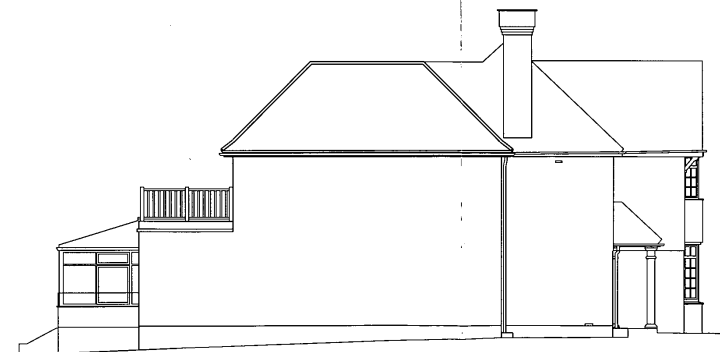

Side Elevation

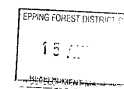

A: 11.08.16 Enlarged size of proposal

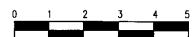

**JSP Chartered Town Planner  
and Design Consultants**  
1 Bantons Yard,  
High Street, Ongar,  
Essex CM5 9AA  
T 01277 366886  
F 01277 366864



Site Lestrem, Dunmow Road,  
Fyfield, Ongar CM5 0NN

Title Proposed 2 storey side  
extension

Drawing Proposed Elevations (2 of 2)

Scale 1:100 @ A3  
Date Apr 2016  
Number 878.28A